

OG122964

## **80,000 Cubic Meters of Concrete: Revit and Dynamo for Project Managers**

Fabio BITETTO  
Maire Tecnimont

Elisa BACCHI  
Maire Tecnimont

Marco Mellacqua  
Maire Tecnimont

Luca VIRNO  
Maire Tecnimont

### **Learning Objectives**

- Understand how to plan, monitor, and determine the project progress and the construction work front with Revit and Dynamo
- Learn how to use Revit to coordinate engineering and construction activities on a real megaproject
- Learn how to use Dynamo to manage custom data built inside your models
- Learn how to visually track your project growth

### **Description**

In an engineering, procurement, and construction context, the project manager is asked to plan, monitor, and determine the project growth in order to manage the process, and eventually take remedial action if required. This difficult activity can be simplified and supported using Revit software and Dynamo software in order to automate the extraction of project progress curves. To achieve this goal, it is necessary to build your Revit models for the hosting of useful data that are then managed through Dynamo. The final outputs consist of reports that can be shared with management whenever requested or required. With this approach, the project can be accurately planned and continuously monitored, and its status can be easily shared. This class will show the application of this methodology on a large industrial plant currently under construction in the Middle East.

## Speaker(s)

Fabio BITETTO

Civil and Structural Underground Engineer - Maire Tecnimont

Fabio is a Structural and Underground Engineer at Maire Tecnimont a worldwide general contractor specialized in the oil & gas and petrochemical industry. He received his master's degree in Building Systems Engineering from the "Politecnico di Bari", Italy. Despite his young age, Fabio made several work experiences in which he grown his BIM and project management expertise focusing especially on energy and utilities. He also collaborated with the City of Milan for the European project "Horizon 2020", focused on smart cities and energy efficiency. In the last year he has become the Company focal point for computational design.

f.bitetto@tecnimont.it

Elisa BACCHI

Civil and Architectural Group Leader - Maire Tecnimont

Starting as university researcher, Elisa Bacchi took the specialization in Industrial Plant civil engineering in 2001, finalizing the main work experiences with Maire Tecnimont Group since 2006. Tecnimont is a leading provider of Engineering & Construction, Technology & Licensing, and Energy Business Development & Ventures worldwide, with a specific focus on the oil & gas. Working as technical engineer and project coordinator about civil and architectural design for some of largest Industrial Complex under Tecnimont Construction scope of work, she was appointed Civil Project Leader since 2010, and Civil and Architectural Group Leader since 2013. She is the lead of Tecnimont BIM System Methodology Development since 2010.

e.bacchi@tecnimont.it

Marco MELLACQUA

Civil and Architectural Engineer - Maire Tecnimont

Marco is a Civil and Architectural Engineer at Maire Tecnimont a worldwide general contractor with a specific focus on the oil & gas, petrochemicals and fertilizer processing industries. He obtained his master's degree at Politecnico di Milano with thesis abroad on Building Information Modeling and Management at Northumbria University (UK). During the degree activities he collaborated to the research project, funded by the Italian Ministry of Economic Development, for setting up the Italian BIM construction database in order to push a radical innovation into the Italian construction sector. In the last years he is strongly involved in BIM methodology development, focusing on civil and structural workflows in the industrial plant design.

m.mellacqua@tecnimont.it

Luca VIRNO

Civil and Structural Underground Engineer - Maire Tecnimont

Luca is a Structural and Underground Engineer and BIM developer at Maire Tecnimont (Oil and Gas/Energy International Player). He obtained Bachelor's degree at Politecnico of Bari and master's degree at Politecnico of Milan in Building Systems Engineering. Luca developed the dissertation on Building Information Modeling and Management at the BIM Academy of Northumbria University. He took also part at the research project "Innovance", funded by the Italian Ministry of Economic Development for setting up the Italian BIM construction database, in order to push a radical innovation into the Italian Construction sector. In the 2014 Luca started the development of BIM in Maire Tecnimont, focusing on Underground Services. Actually he is involved in the definition and application of department's Standard and Methodology on the ongoing Projects.

[l.virno@tecnimont.it](mailto:l.virno@tecnimont.it)

## **About Maire Tecnimont Group**

Maire Tecnimont is a multinational and multicultural Group comprising approximately 8,000 professionals in 45 operating companies in over 30 countries. Listed on the Milan Stock Exchange since 2007 and rooted in well-recognized Italian engineering brands, the Group is among the top-ranking worldwide players in our markets. We focus on our distinctive competences and technologies in the petrochemicals, oil & gas, fertilizer and power generation plants. Our group covers the entire value chain from end to end, delivering full EPC turnkey complex projects and offering a variable mix of service with high flexibility to maximize local content in every part of the world. Our vision is to be a world-class technology-driven, Engineering, Procurement and Construction Contractor. We want to make competence entrepreneurship and adaptiveness our key success factors.

## **Understand how to plan, monitor, and determine the project progress and the construction work front with Revit and Dynamo**

In the Industrial Plant market the handover of a 3D Model is a standard practice driven by contractual requirements. Specific guidelines are defined for the effective and uniform application of 3D Modeling to all Plant items together with the required software. Together with those guidelines are defined also the 3D Model Design Reviews in order to check the status and quality of the design, to manage inter-discipline interfaces and to support efficient and timely production of deliverables.

After a couple of early test on small projects the methodology has been fully integrated in a project for the realization of a Polyethylene Plant (HDPE/LLDPE) and a Polypropylene Plant (PP) on an EPC basis of the value of USD 895 million in Oman.

The main actor of this development has been the Civil & Structural Department that integrates Revit and Dynamo in the design process that previously was developed fully in 2D.

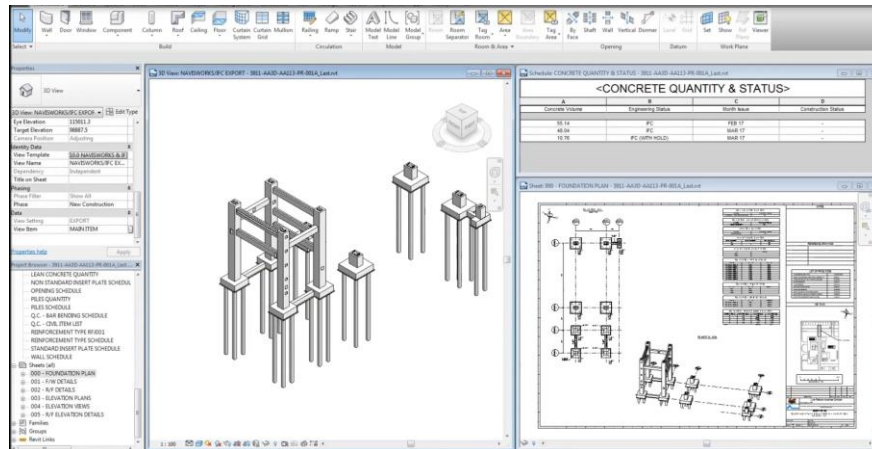

*Example of Structural Main Item Model*

As part of the BIM development project, the team has also dealt with issues related to the key information management of the project. Given the size of the documents issued and the front work to be handled over the years of design, the model can be the absolute protagonist. Like a white canvas customized with your own data that can return an updated picture of the project and its evolution.

## Learn how to use Revit to coordinate engineering and construction activities on a real megaproject

Modeling strategy is the key to the success of a project especially in a megaproject. At the start of the activities, you want to gather as much information about project equipment in the early phases of design – preferably in schematic design. The size, orientation, clearance and access requirements drive the design in this scenario.

So start with your equipment list. Traditionally, this is made up of a spreadsheet, which lists the key ingredients and adds some basic data. With this list we will create Main Item Models for equipment that requires a structure.

Each Main Item Model born as a preliminary “dummy” model for populating the entire Plant 3D Model and check in early stage the layout consistency in order to spot challenges earlier. This allows the Project Team to make, in a 3D environment, the Plant Layout optimization in a timely and cost-effective manner. All the “dummy” models are then detailed following the planned engineering progress. From each Model are extracted Construction Drawings, MTOs and other Project Management deliverables such as “3D-Model Progress”, “Engineering Status”, etc.

All the Main Item Models are linked in a single environment, the Assembly Model. Here, all the previously compiled and up-to-date information can be easily handled for analysis, study, or simple extraction.

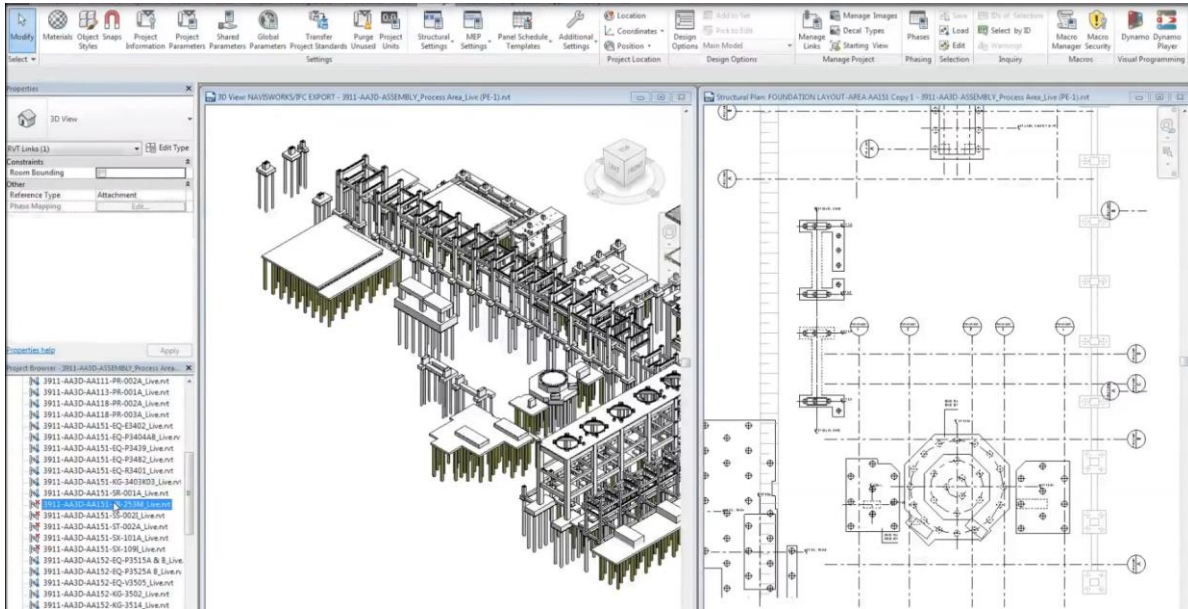

*Example of Assembly Model*

This data driven approach is the core of the integration and coordination. It offers control, visibility and efficiency reducing at the same time the project risks. Revit models contain extensive amounts of rich and intelligent data and the use and application of these Revit models are virtually endless. Revit and especially Dynamo offer the possibility to take full control of the project data for civil design in:

- **Key Quantities monitoring:** the Revit Assembly file (Revit Links Collection) allows to the project coordinators to have full control of key quantities per civil item or per WBS. This helps in keep the quantity balance under control and takes action when required.
- **Indexes Monitoring:** Usually the schedules are tight and sometimes the hurry can affect the design. In this scenario, Dynamo is a powerful tool to read and compare quantities of different objects, generating indexes useful to the Project Specialists. It is possible, for instance, to compare concrete and reinforcement quantities in order to check their ratio and consequently the principles of good design avoiding materials waste.
- **Accounting Automation:** The accounting process in an EPC scenario is always a tedious long-winded procedure. With a pushed standardization of Revit Contents and applying the computational power of Dynamo and C# Coding it is possible to reduce the effort and save precious time.
- **Project Planning:** In an EPC project the division of the works in construction lots is necessary to meet the scheduled targets. The civil “dummy” modeling helps to split the Plant in construction lots. This step gives to all the involved actors a clear picture of the scope of work together with the related preliminary quantities in a very early stage.

- **Constructability Analysis:** In a mega-project like an Industrial Plant there are thousands of deliverables and keep traceability of the engineering status of the documents is difficult. In a BIM process deliverables are extracted directly from the model so it takes a blinking of an eye to assign the engineering status to the modeled objects. This procedure can be improved automating it with a Dynamo Script. Once the information are set, it is possible to extract them in a list or visualize them applying color legends, simplifying constructability analysis and speeding up the work at site.
- **Project Progress:** In an EPC context it is necessary to plan, monitor and determine the project growth in order to manage the process and eventually take remedial action if required. This difficult activity can be simplified and supported automating the extraction of the project progress curves. It is necessary to set up the Models for hosting the required data and then take, sort and export them through Dynamo in order to obtain output sheet to share with the Project Managers.



<CONCRETE QUANTITY & STATUS>			
A	B	C	D
Concrete Volume	Engineering Status	Month Issue	Construction Status
55.14	IFC	FEB 17	-
48.04	IFC	MAR 17	-
10.76	IFC (WITH HOLD)	MAR 17	-

*Example of custom data built in Revit*

## Learn how to use Dynamo to manage custom data built inside your models

Dynamo is a visual programming extension for Autodesk Revit that allows you to manipulate data, sculpt geometry, explore design options, automate processes, and create links between multiple applications. Once we've installed the application, Dynamo will enable us to work within a Visual Programming process wherein we connect elements together to define the relationships and the sequences of actions that compose custom algorithms. We can use our algorithms for a wide array of applications - from processing data to generating geometry.

Dynamo for Revit extends building information modeling with the data and logic environment of a graphical algorithm editor. Its flexibility, coupled with a robust Revit database, offers a new perspective for BIM.

Through dynamo we will extract the data in the assembly model, so that it can be used for external analysis.

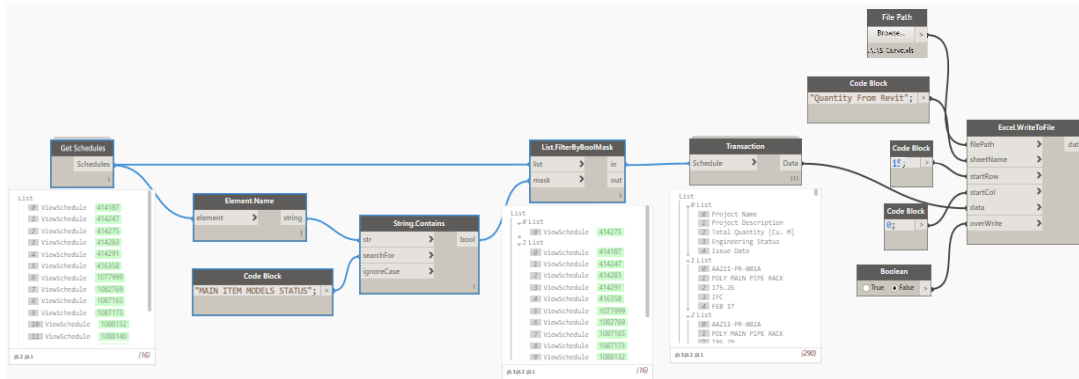

*Capture of our Dynamo Script*

Our Dynamo Script is composed by three parts:

- Extract all the schedules created in the Assembly Model and then filter in order to select the one needed for a specific analysis.
- Convert the view schedules in lists of data.
- Export data in Excel file.

## Learn how to visually track your project growth

Inside the excel file where we will include the data coming from Revit, it will be possible to analysis and monitor the design progress using the S-Curve.

S-curve is an important project management tool. They allow the progress of a project to be tracked visually over time, and form a historical record of what has happened to date. Analyses of S-curves allow project managers to quickly identify project growth, slippage, and potential problems that could adversely impact the project if no remedial action is taken.

Comparison of the Target S-curve and Actual S-curve reveals the progress of the project over time. In most cases, the Actual S-curve will sit below the Target S-curve for the majority of the project (due to many factors, including delays in updating the production schedule). Only towards the end of the project will the curves converge and finally meet. The Actual S-curve can never finish above the Target S-curve. If the Actual S-curve sits above the Target S-curve at the Cut Off Date, the Production Schedule should be examined to determine if the project is truly ahead of schedule, or if the Production Schedule contains unrealistic percentage complete values for ongoing tasks.





The same type of analysis can be made in Navisworks a powerful tool also to review and track visually data. In this environment you can create sets, groups that share common properties, which can make it easier to review and analyse information throughout the design process. For example in below case, structure issued for construction are marked in green, instead the ones issued with old are marked in red.

Structures in a dummy status are not marked.

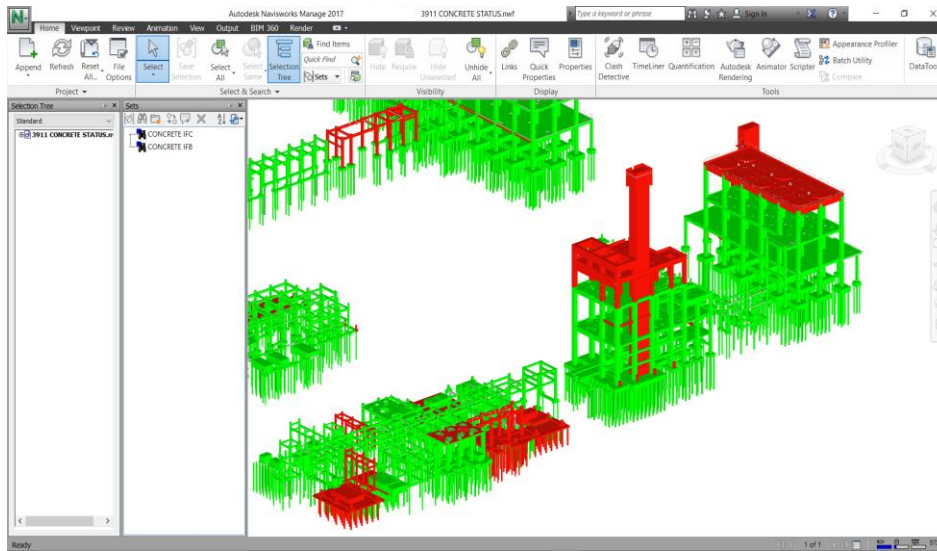

*Example of Navisworks Visualization*